

Weld-on-Hubs

Taper Bore Weld-on-Hubs are made out of steel, drilled, tapped and taper bored to receive standard Taper Bushes. The extended flange provides a convenient means of welding hubs into fan rotors, steel pulleys, plate sprockets, impellers, agitators and many other devices which must be firmly fastened to the shaft.

Weld-on-Hubs are easy to install and entirely suitable for use where severe operating conditions are met. Tightening the screws contracts the bore of the bush, thereby locking it to the shaft with the equivalent of press fit. This type of construction eliminates mounting difficulties, it also prevents loosening and wear on the hub during operation.

Challenge Weld-on-Hubs are manufactured to complement the Taper Bush range and include W, WG, WH, WHG, WM and WMG Taper Bore Hubs. All are manufactured to world standards using C45 steel.

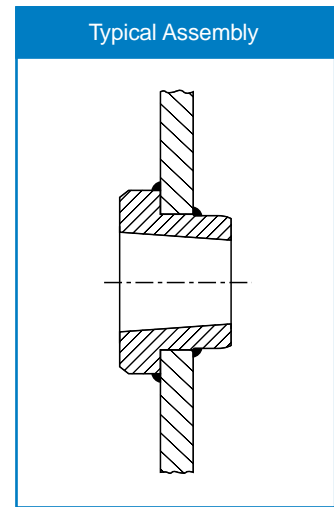
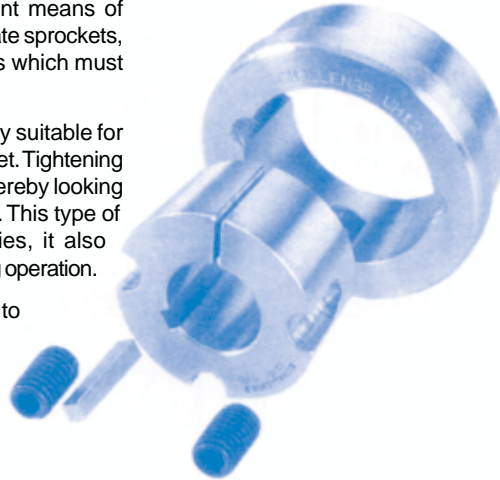

W Weld-on-Hubs

Hub Reference	Bush Number	A	B	C	D	E	F
W12	1215	73.03	63.50	62.71	38.10	15.88	9.53
W16	1615	82.55	73.03	72.24	38.10	15.88	9.53
W20	2017	101.60	80.90	88.11	44.45	19.05	14.45
W25	2517	127.00	111.13	110.34	44.45	19.05	12.70
W30	3030	149.86	133.35	132.56	76.20	25.40	19.05
W35	3535	184.15	158.75	157.96	88.90	31.75	25.40
W40	4040	225.43	196.85	196.06	101.60	31.75	31.75
W45	4545	254.00	222.25	221.46	114.30	38.10	38.10

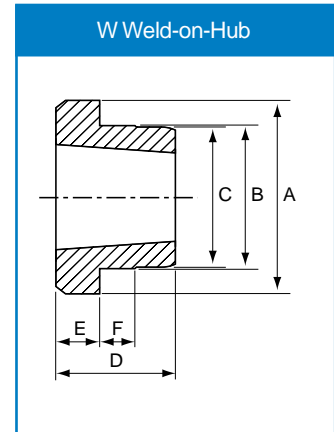

WG Weld-on-Hubs

Hub Reference	Bush Number	A	B	C	D	E	F	F1	X
WG12	1215	73.03	63.50	62.71	38.10	15.88	9.53		
WG16	1515	82.55	73.03	72.24	38.10	15.88	9.53		
WG20	2017	101.60	88.90	88.11	44.45	19.05	14.45		
WG25	2017	127.00	111.13	110.34	44.45	19.05	12.70		
WG30	3030	149.86	133.35	132.56	70.20	25.40	19.05	25	19
WG35	3535	184.15	158.75	157.96	88.90	31.75	25.40	31	22
WG40	4040	225.43	196.85	196.06	101.60	31.75	31.75	37	22
WG45	4545	254.00	222.25	221.46	114.30	38.10	38.10	44	15

"G" notation represents welding relief.

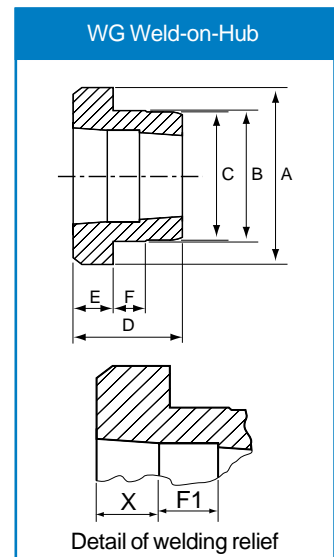

Weld-on-Hubs

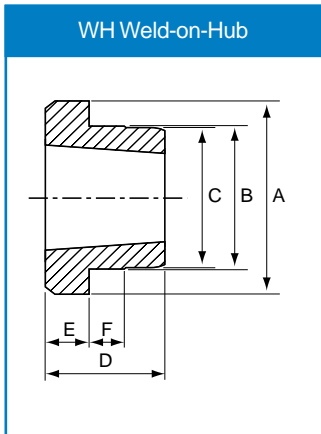

WH Weld-on-Hubs

Hub Reference	Bush Number	A	B	C	D	E	F
WH12	1210	70	65	64.5	25	9	10
WH16-1	1610	80	75	74.5	25	9	10
WH20	2012	95	90	89.5	32	12	12
WH25	2517	115	110	109.5	44	19	15
WH30-2	3020	145	140	139.5	50	20	15
WH35	3525	190	180	179.5	65	25	25
WH40-1	4030	200	190	189.0	76	32	30
WH40-2	4040	200	190	189.5	101	32	30
WH45-1	4535	210	200	190.5	89	40	30
WH45-2	4545	210	200	190.5	114	40	30
WH50-1	5040	230	220	210.5	102	40	35
WH50-2	5050	230	220	219.5	127	40	35

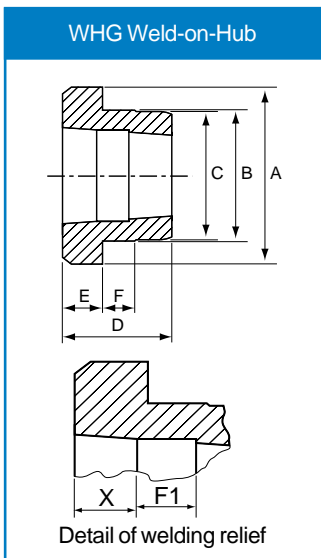

WHG Weld-on-Hubs

Hub Reference	Bush Number	A	B	C	D	E	F	F1	X
WHG12	1210	70	65	64.5	25	9	10	-	-
WHG16-1	1610	80	75	74.5	25	9	10	-	-
WHG20	2012	95	90	89.5	32	12	12	-	-
WHG25	2517	115	110	109.5	44	19	15	-	-
WHG30-2	3020	145	140	139.5	50	20	15	21	14
WHG35	3525	190	180	179.5	65	25	25	31	19
WHG40-1	4030	200	190	189.0	76	32	30	27	22
WHG40-2	4040	200	190	189.5	101	32	30	27	22
WHG45-1	4S35	210	200	199.5	89	40	30	33	25
WHG45-2	4545	210	200	199.5	114	40	30	33	25
WHG50-1	5040	230	220	219.5	102	40	35	37	29
WHG50-2	5050	230	220	219.5	127	40	35	37	20

"G" notation represents welding relief.

Weld-on-Hubs

WM Weld-on-Hubs

Hub Reference	Bush Number	A	B	C	D	E	F
WM12	1210	70	60	58	26	9	10
WM16-1	1010	83	70	68	26	9	10
WM16-2	1615	83	70	68	38	10	11
WM20	2012	95	90	88	32	12	12
WM25	2517	127	110	108	44	19	13
WM30-2	3020	152	130	125	50	20	15
WM30-3	3030	152	130	125	76	25	19
WM35	3535	184	155	151	89	32	25
WM40	4040	225	195	187	102	32	32
WM45	4545	254	220	213	114	38	38
WM50	5050	278	242	228	127	38	38

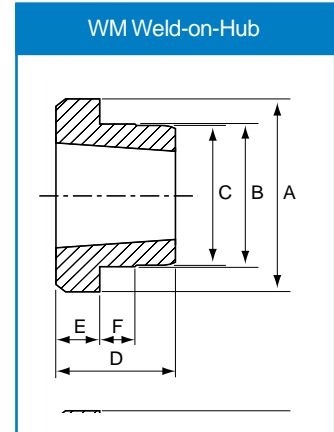

WMG Weld-on-Hubs

Hub Reference	Bush Number	A	B	C	D	E	F	F1	X
WMG12	1210	70	60	58	26	9	10	8	9
WMG16-1	1610	53	70	68	26	9	10	8	9
WMG16-2	1615	83	70	68	38	16	11	8	16
WMG20	2012	95	90	88	32	12	12	10	12
WMG25	2517	127	110	108	44	19	13	10	19
WMG30-2	3020	152	130	125	50	20	15	12	20
WMG30-3	3030	152	130	125	70	25	19	12	25
WMG35	3535	184	155	151	89	32	25	15	32
WMG40	4040	225	195	187	102	32	32	15	32
WMG45	4545	254	220	213	114	38	38	20	38
WMG50	5050	276	242	228	127	38	38	20	38

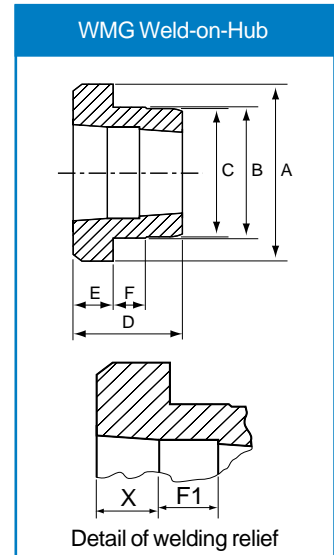

"G" notation represents welding relief.